

1. Cut and bend wire for landing gear using template below. Fit wire into slots and glue F4A to F4 using epoxy.

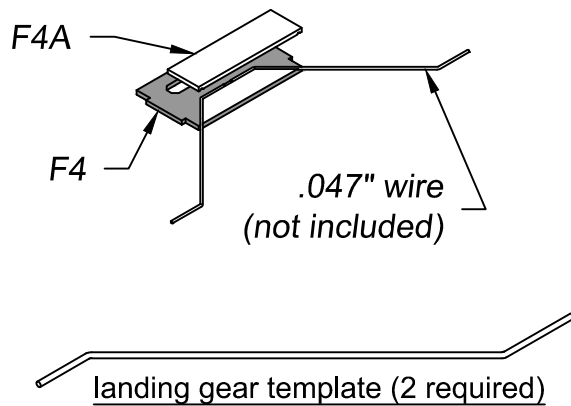

2. Glue two rare earth magnets and $\frac{1}{8}$ " diameter dowel pin (included) into F5. Glue two rare earth magnets into the receiver tray.

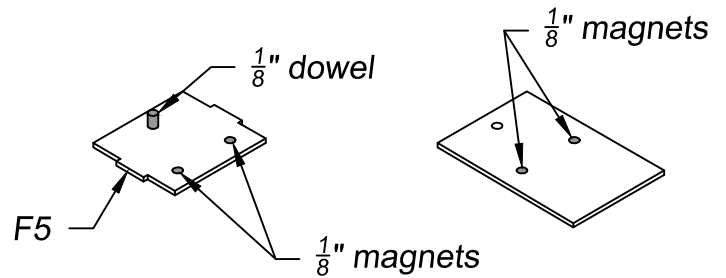

3. Use scrap balsa strips to glue cross grain reinforcements to F6 and F7.

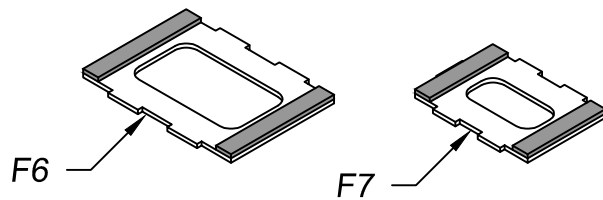

4. Screw motor mount to F2, harden screw holes with thin CA. Fit and glue F2 and F3 to battery tray BT.

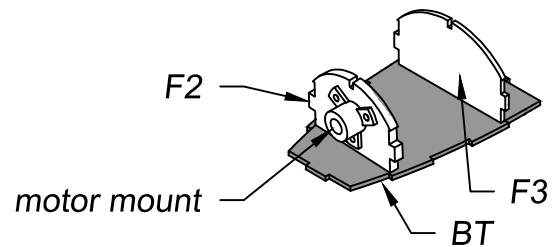

5. Fit battery tray assembly and F4-F8 to fuselage side FR. Tack glue if necessary to hold parts in place.

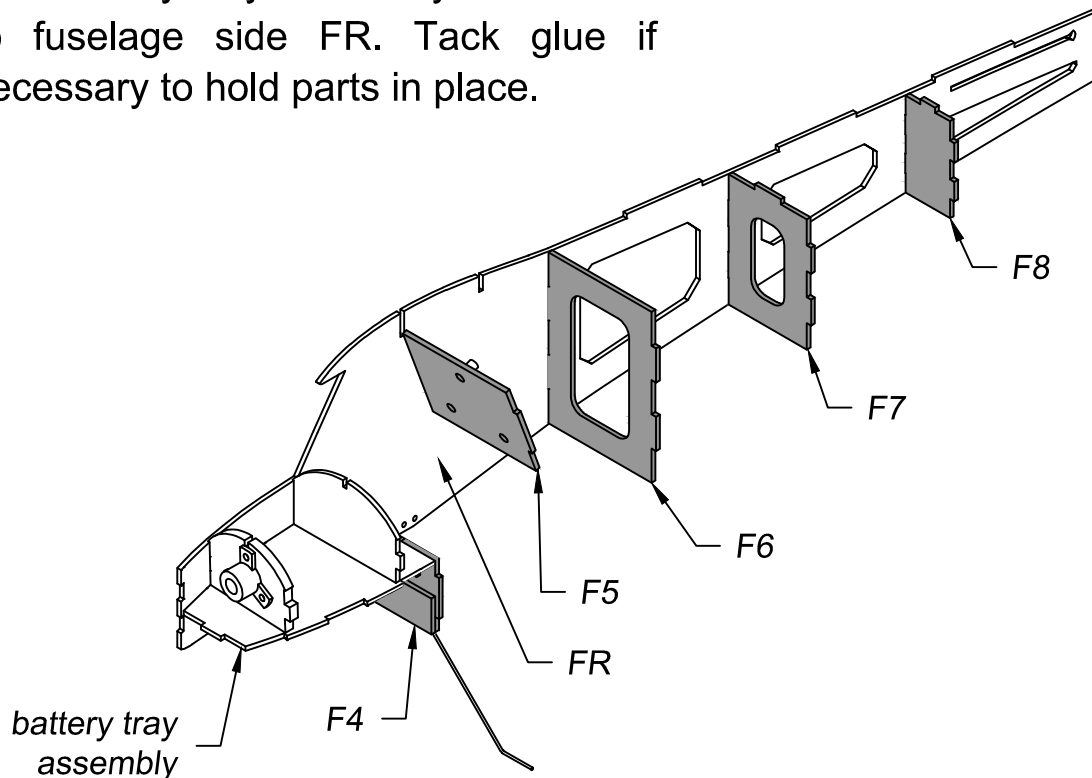

6. Fit the left fuselage side FL, ensure that all parts are fully seated in their slots and glue formers F2-F6 and the battery tray BT to fuselage sides. Do not glue F7 and F8 to the fuselage sides yet. On the rear of the fuselage, sand a slight bevel on the inside edge of the fuselage sides. Tape the rear of the fuselage together.

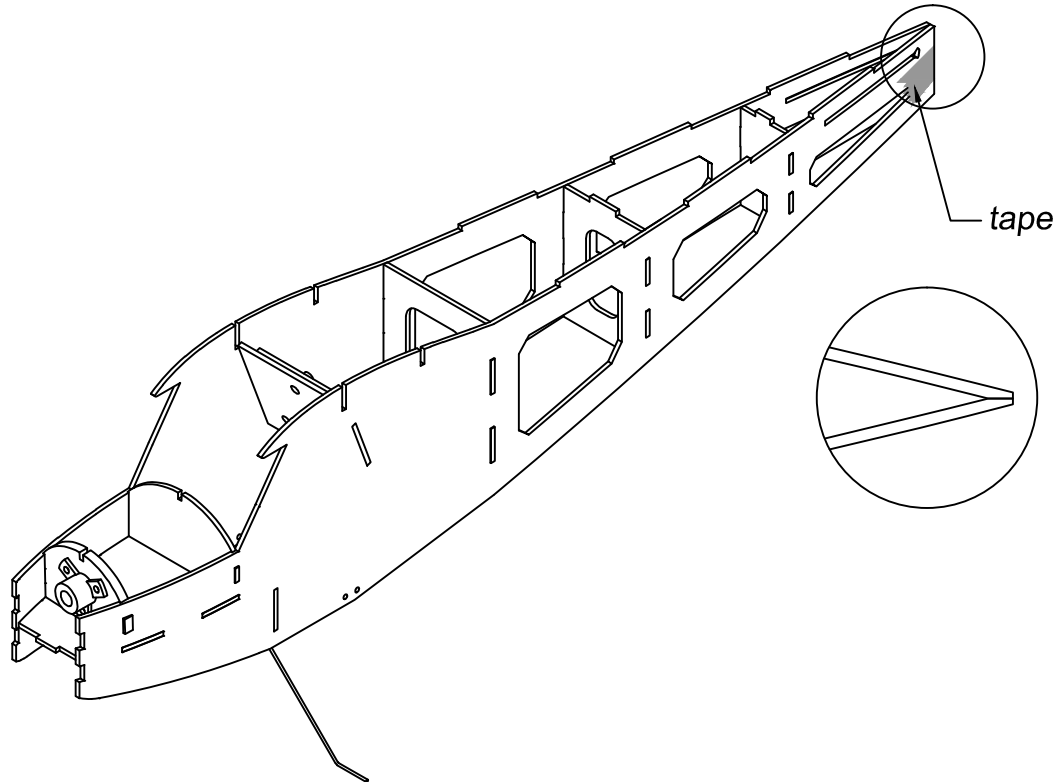

7. Fit and glue F1 to BT and the fuselage sides. Fit and glue S1 into the slots in F1, F2 and F3.

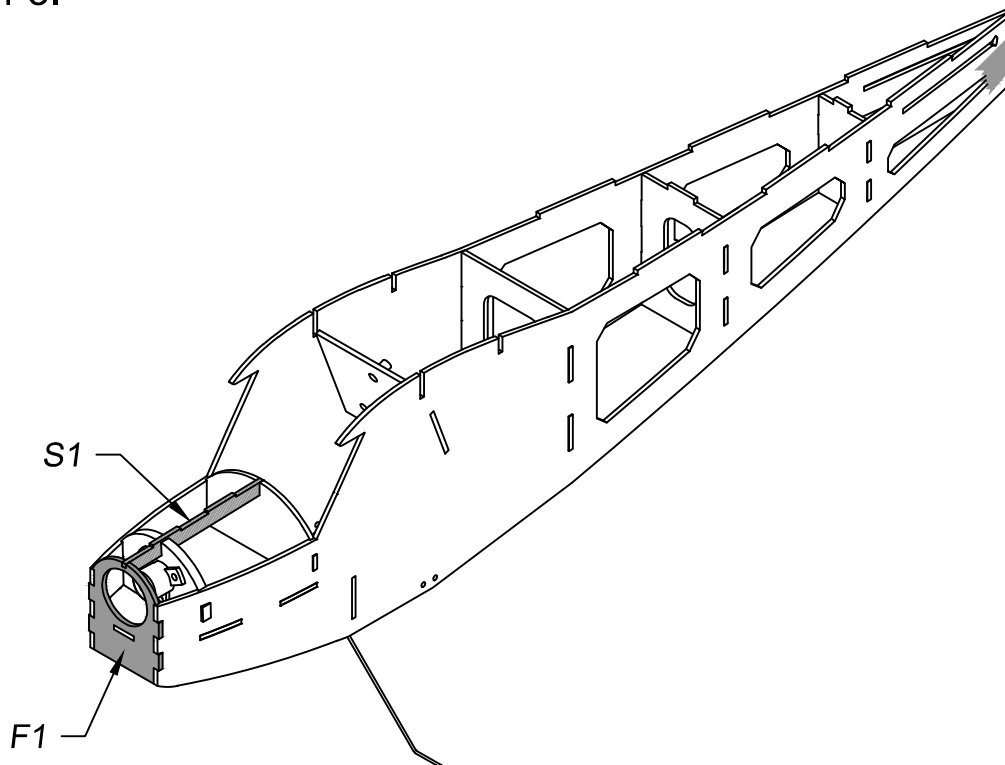

8. Fit and glue D1 and D2 to fuselage sides and formers. Glue rear of fuselage sides together and remove the tape.

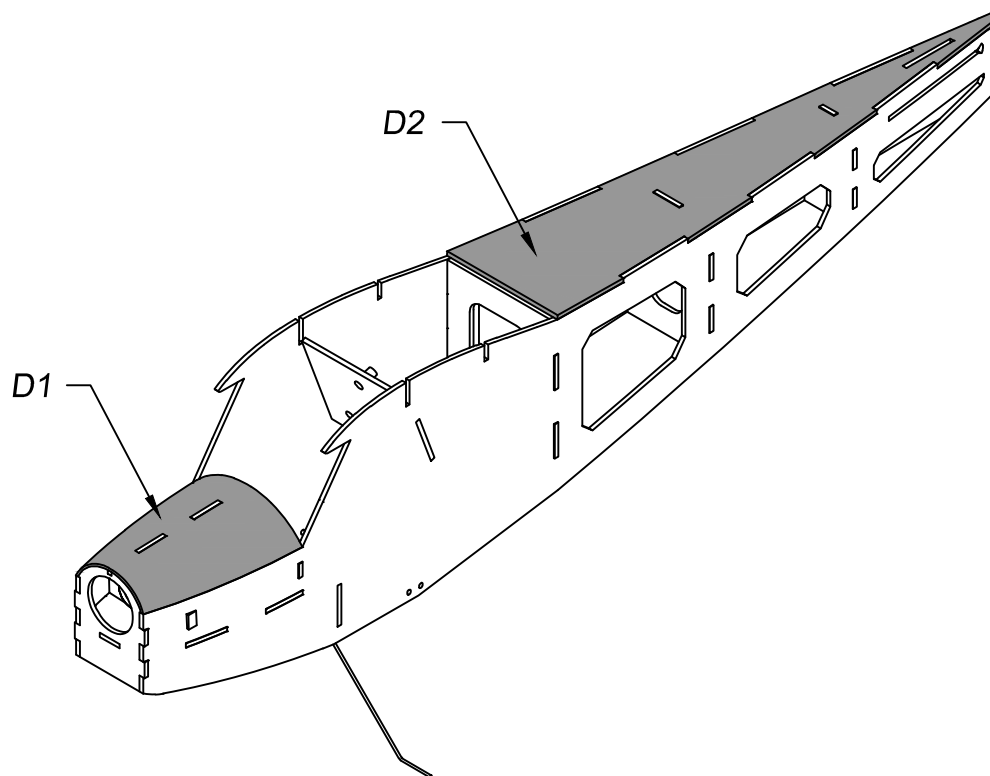

9. Glue $\frac{1}{4}$ " (6mm) balsa nose blocks to F1 and sand balsa nose blocks to shape. Sand fuselage to prepare for covering.

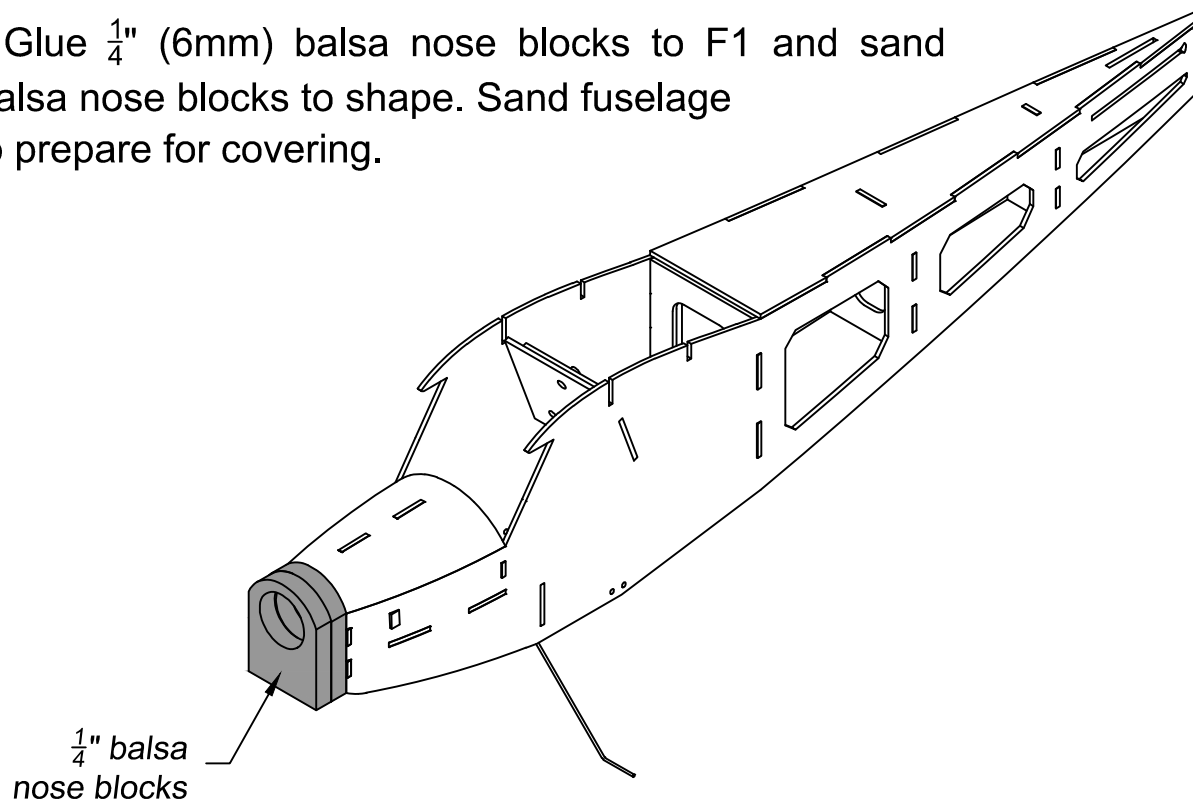

10. Cover the fuselage. Trim covering from the horizontal and vertical stabilizer slots and also from the wing spar slots.

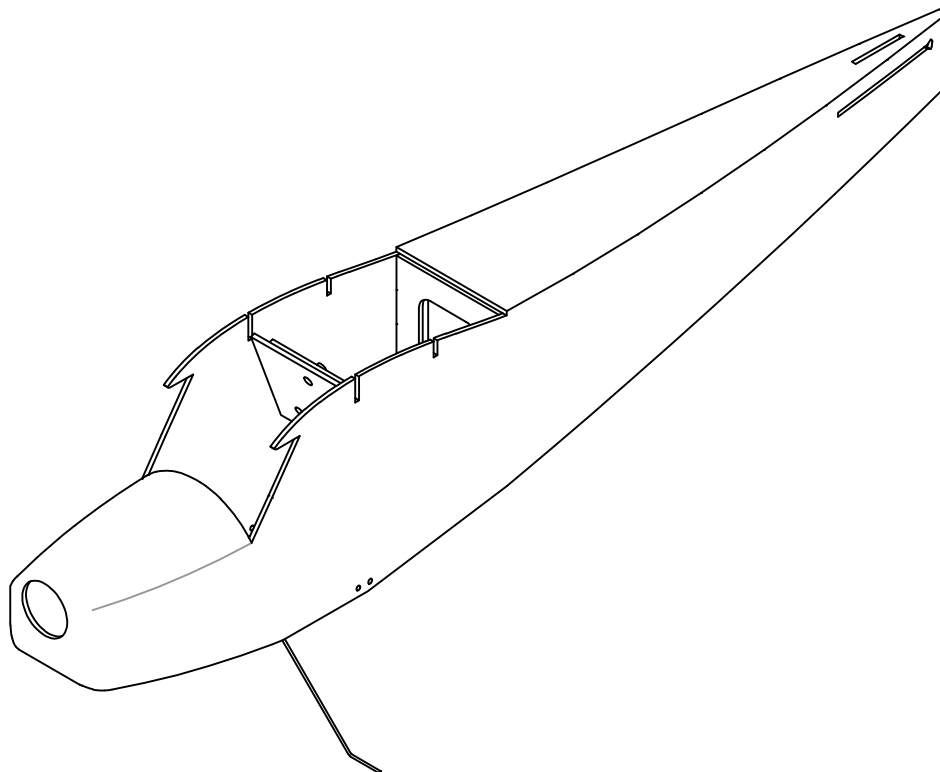

11. Assemble the horizontal and vertical stabilizers.

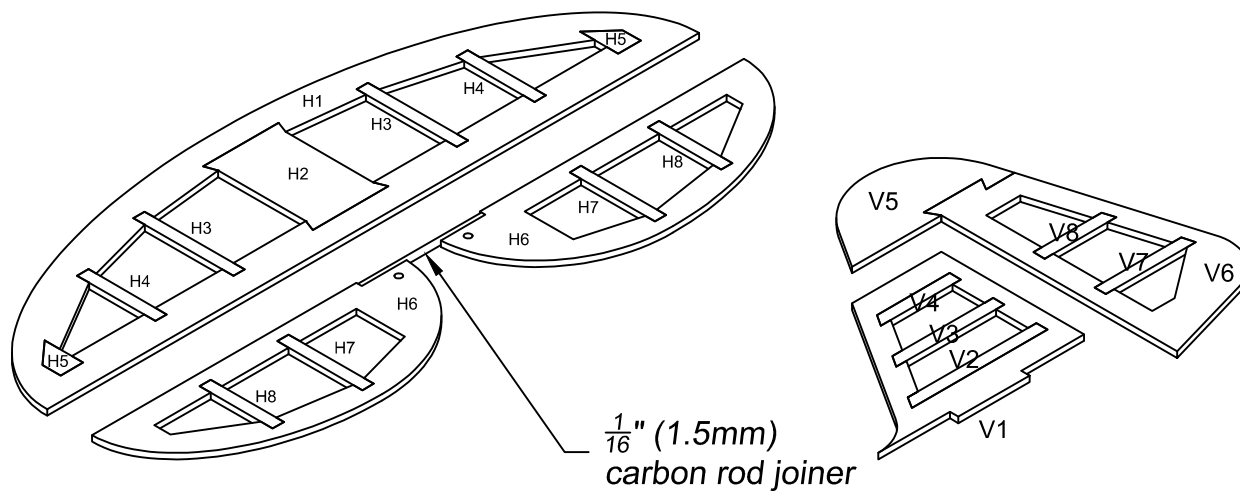

12. Fit ribs R1 into the slots in WS1 and WS2. DO NOT glue yet!

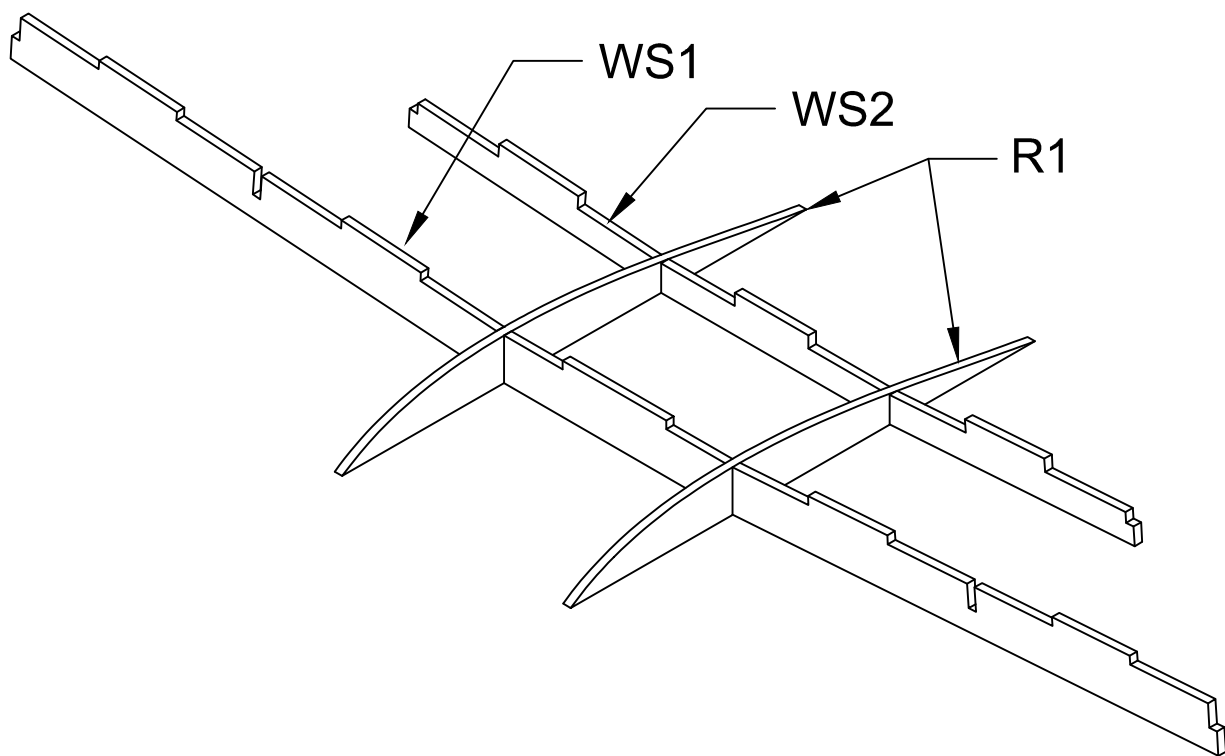

13. Fit and glue W1A and W1B together to form center wing sheeting. Fit W1 onto the tabs on WS1 and WS2. Keep on a flat surface and glue W1 to WS1, WS2 and ribs R1.

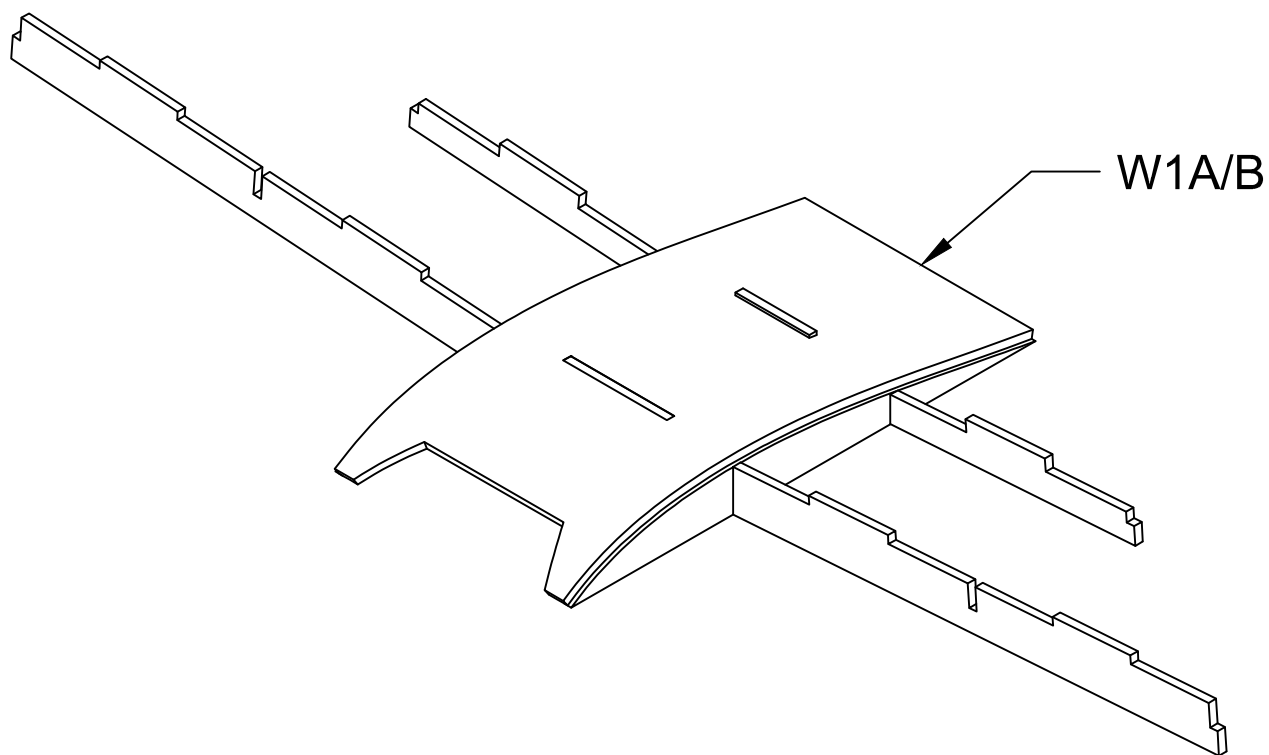

14. Fit and glue the two wing panels together.

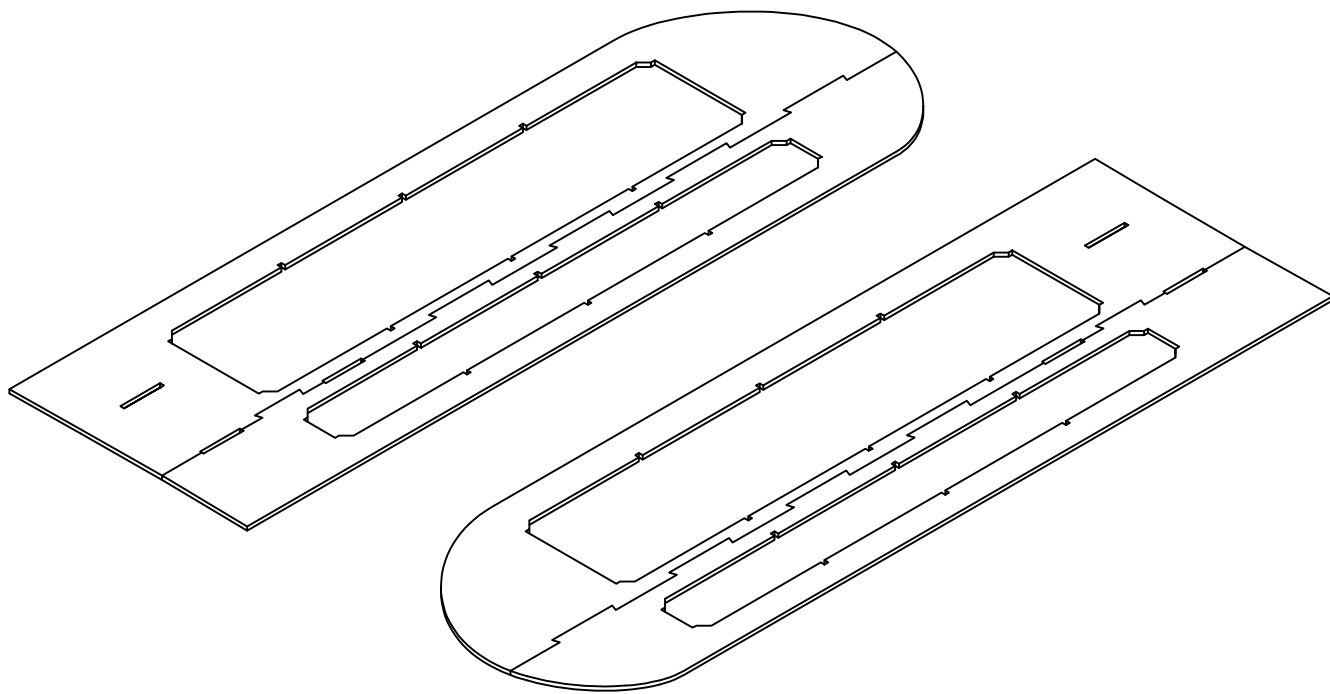

15. Fit and glue ribs R2 - R6 to the wing panels, starting at the trailing edge. Be sure to make a left and right wing panel.

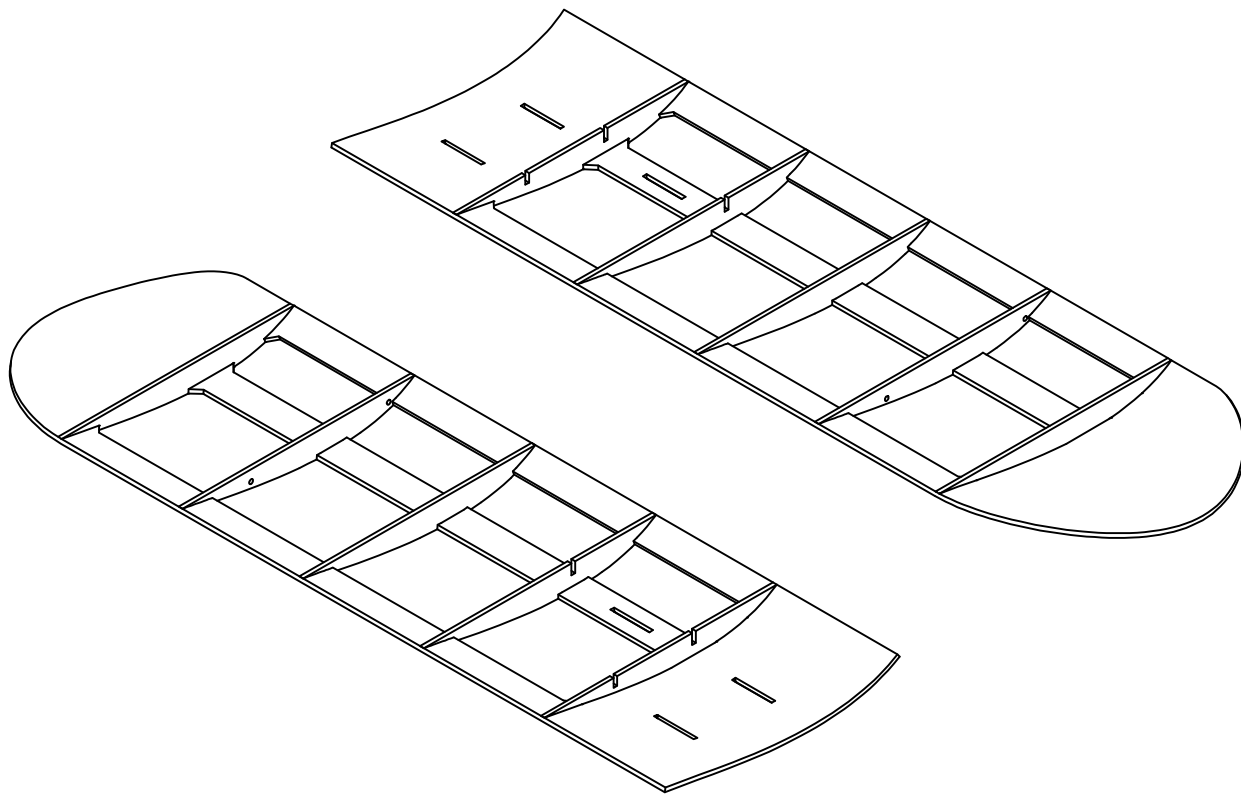

16. Fit and glue the right and left wing panels to the wing center section.

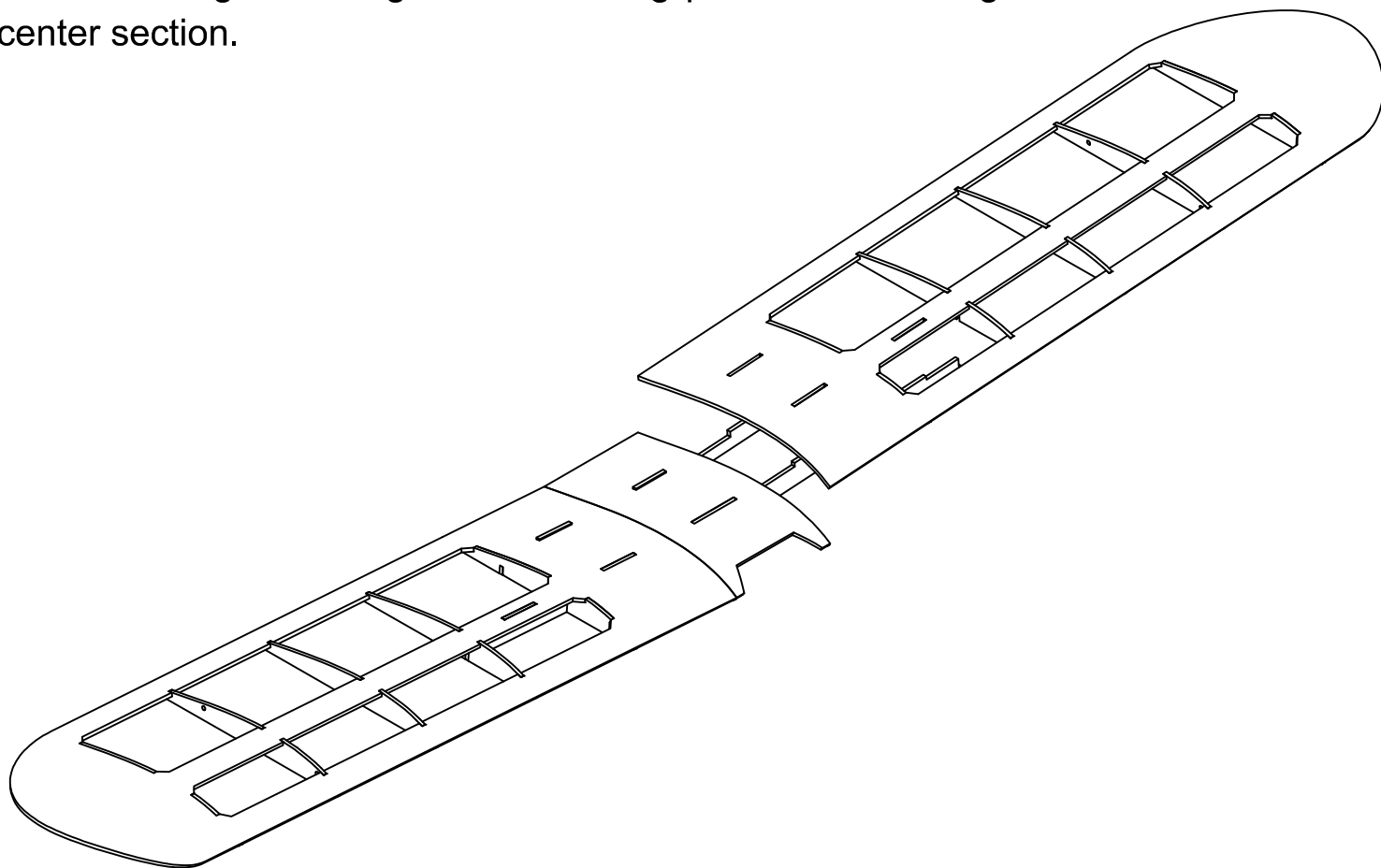

17. Glue the $\frac{1}{16}$ " (1.5mm) balsa leading edge strip to the left and right wing panels.

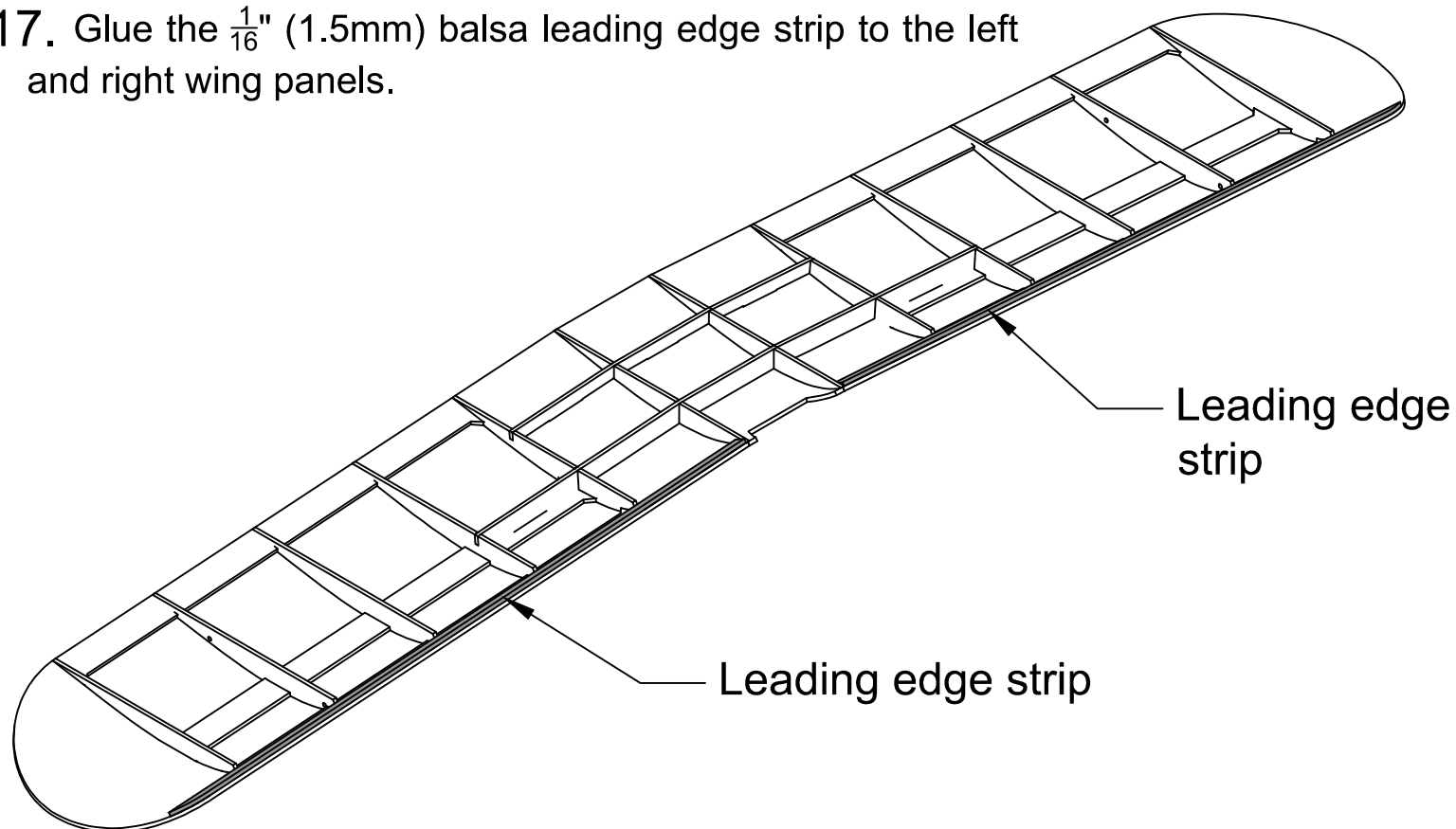

18. Cover the top surface of the wing, horizontal and vertical stabilizers and control surfaces before final assembly.

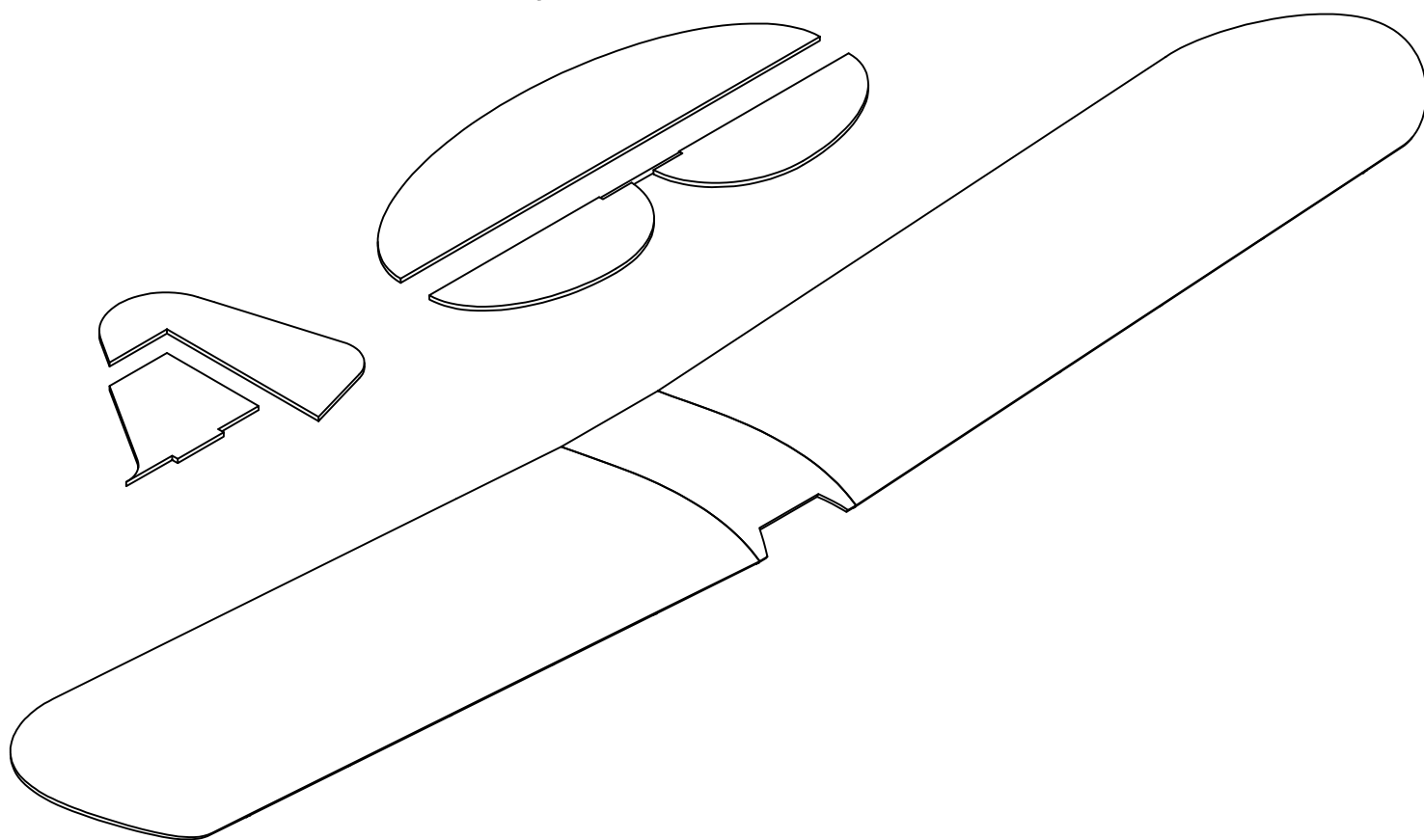

19. Insert the elevator into the horizontal stabilizer slot.

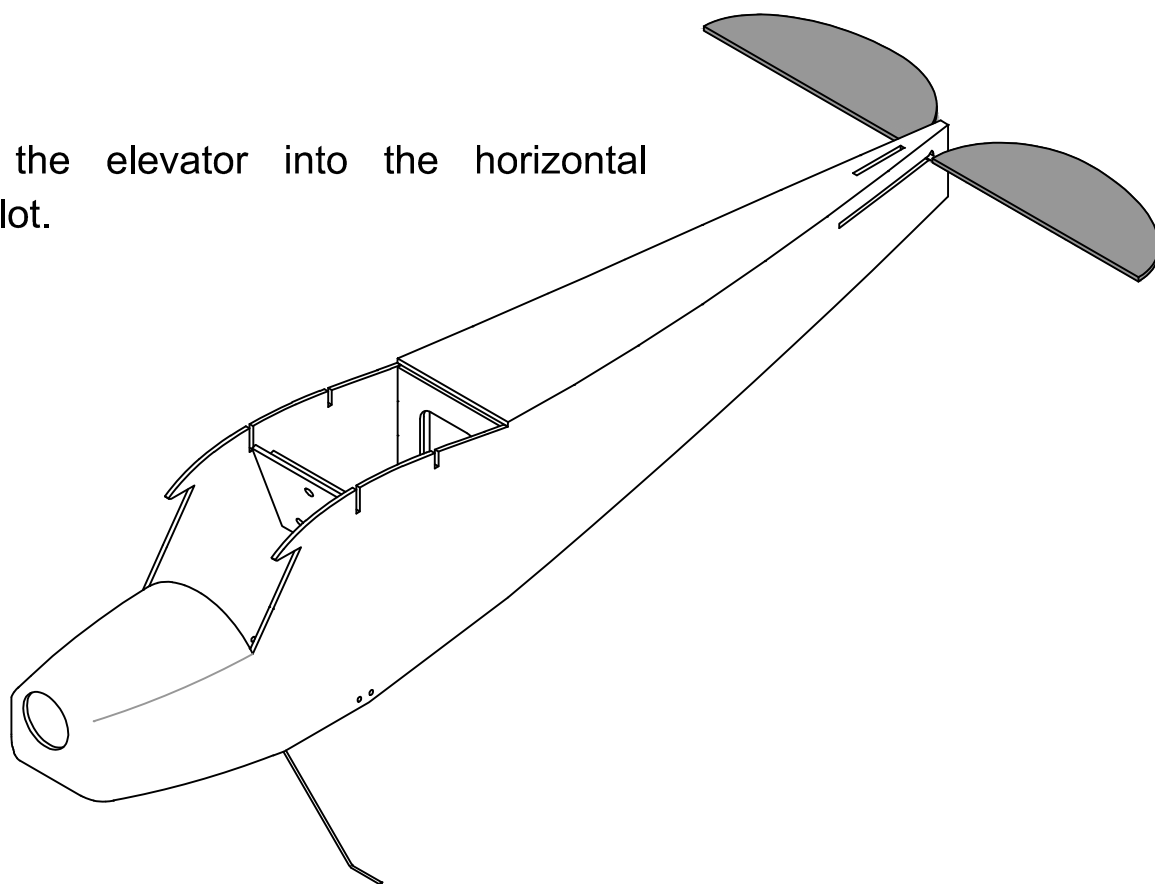

20. Slide the horizontal stabilizer into the slot. Ensure the stabilizer is centered properly and glue to fuselage. Attach the elevator to the stabilizer.

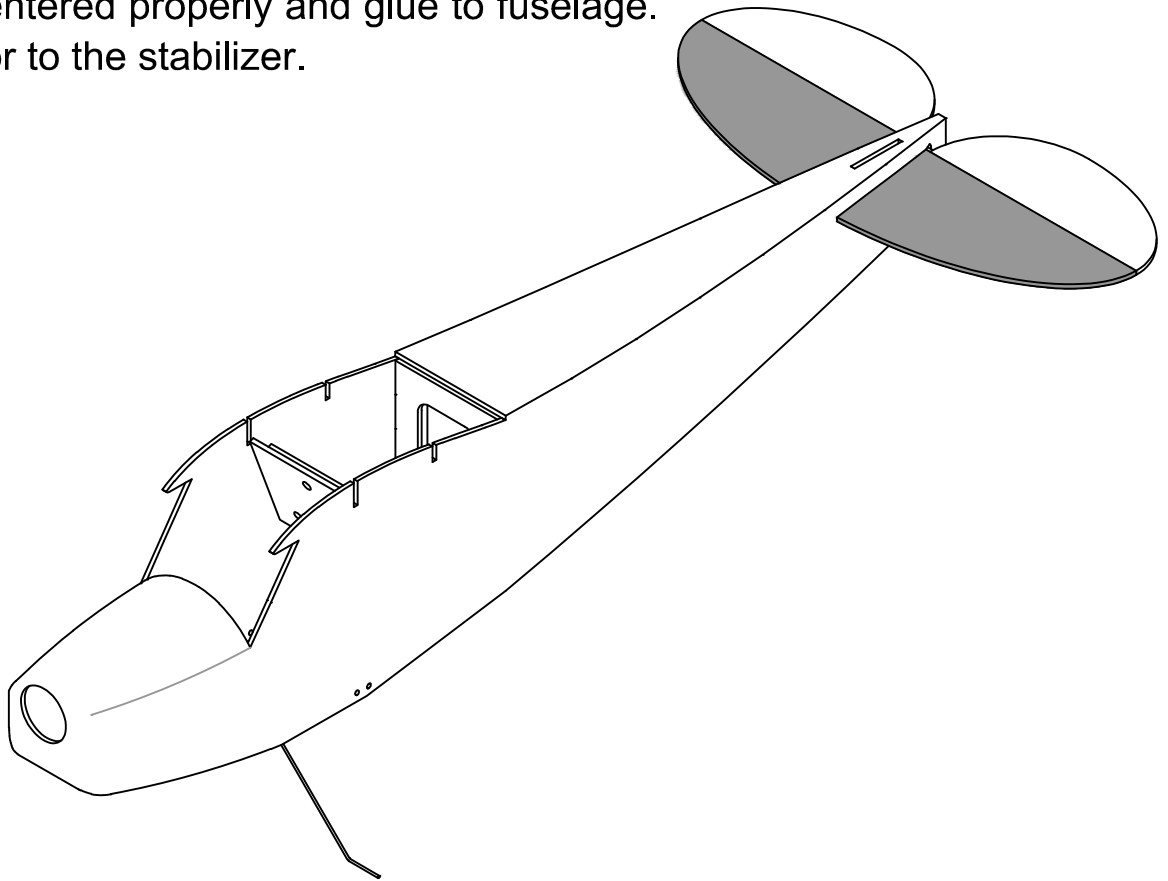

21. Fit the vertical stabilizer to the fuselage. Ensure it is square to the fuselage and horizontal stabilizer and glue in place. Attach the rudder to the vertical stabilizer.

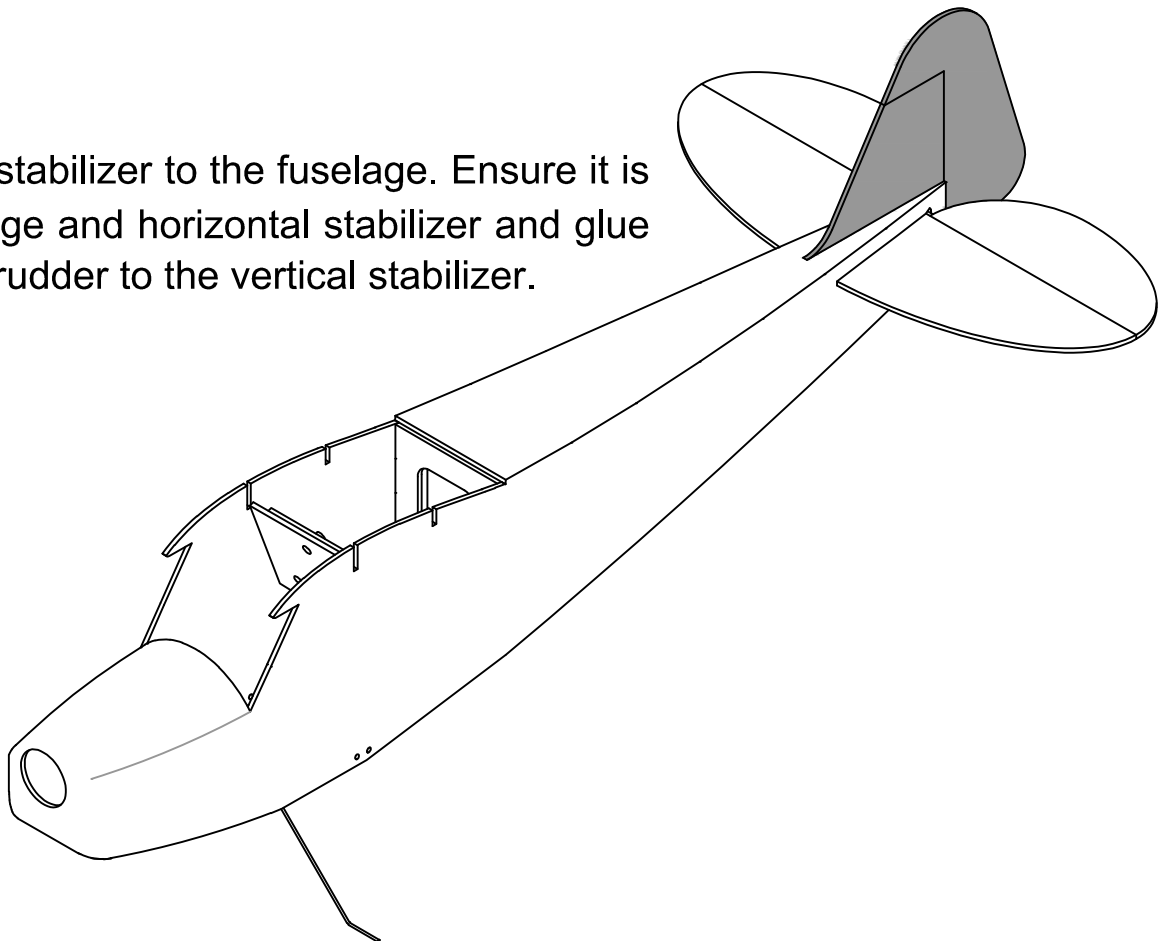

22. Fit the wing to the fuselage. Ensure that it is fully and properly seated and glue in place.

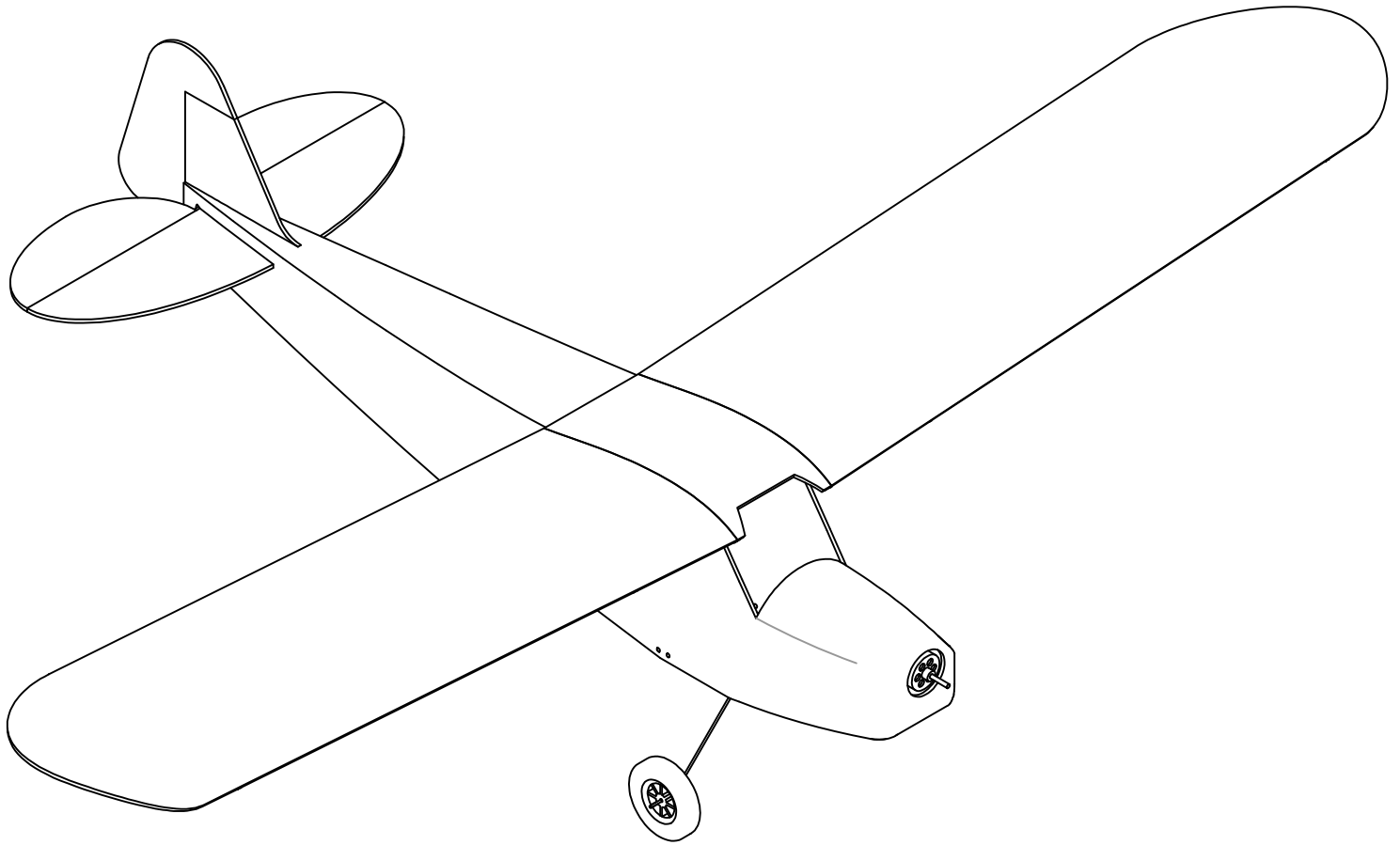

23. Make the dummy engine by gluing the $\frac{1}{16}$ " (1.5mm) ply 'exhaust manifold' to the $\frac{1}{8}$ " (3mm) balsa 'cylinders'. For a J3 Cub and a L-4 scheme, paint the dummy engine black. For a J3 Cub, paint the 'cylinder heads' silver.

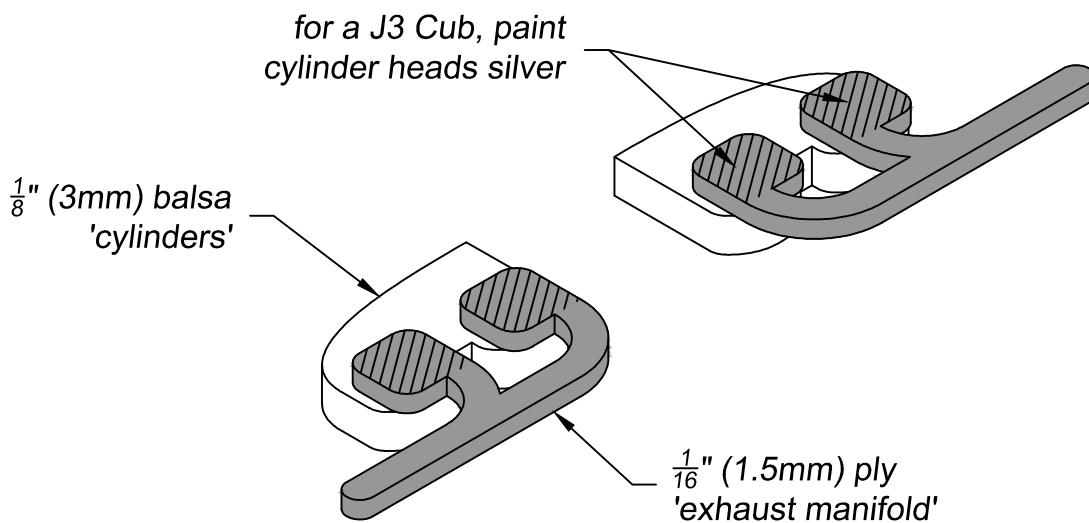

24. Glue the windscreen to the fuselage and wing. Cut four (4) pieces of the $\frac{1}{16}$ " (1.5mm) carbon rod $9\frac{3}{16}$ " (233mm) long for the wing struts. Fit struts into the holes in the fuselage and wing rib R5. Ensure the wings are straight and glue the struts to the fuselage and wing ribs. The struts can be used to add washout to the wing if desired. Glue the dummy engine parts to the fuselage. Cover the landing gear fairings and secure to the fuselage with clear tape or covering material. Add wheels.

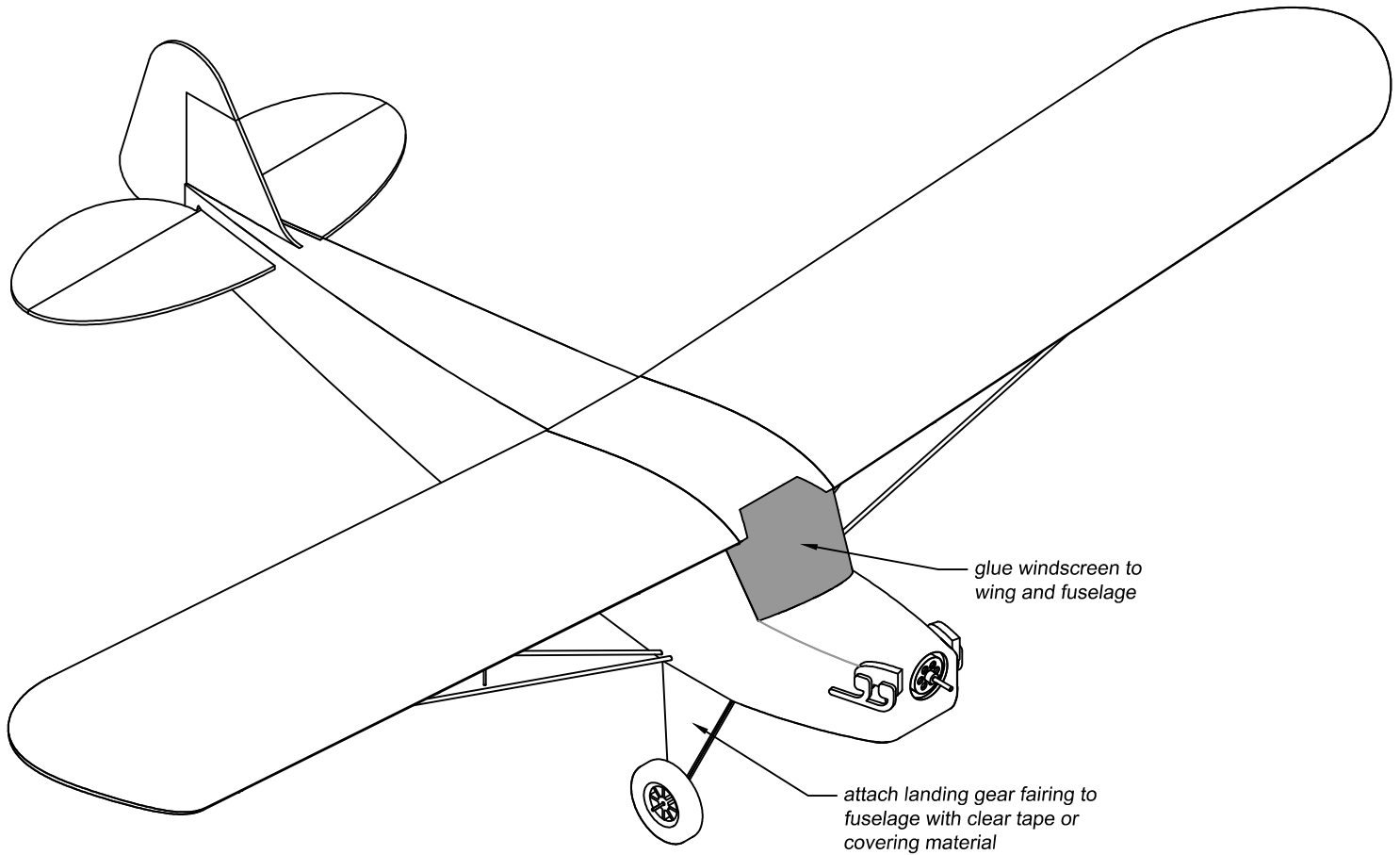

25. Use double sided foam tape to install servos where indicated. Connect servos to control surfaces with 'pin' style control horns and .032" diameter wire.

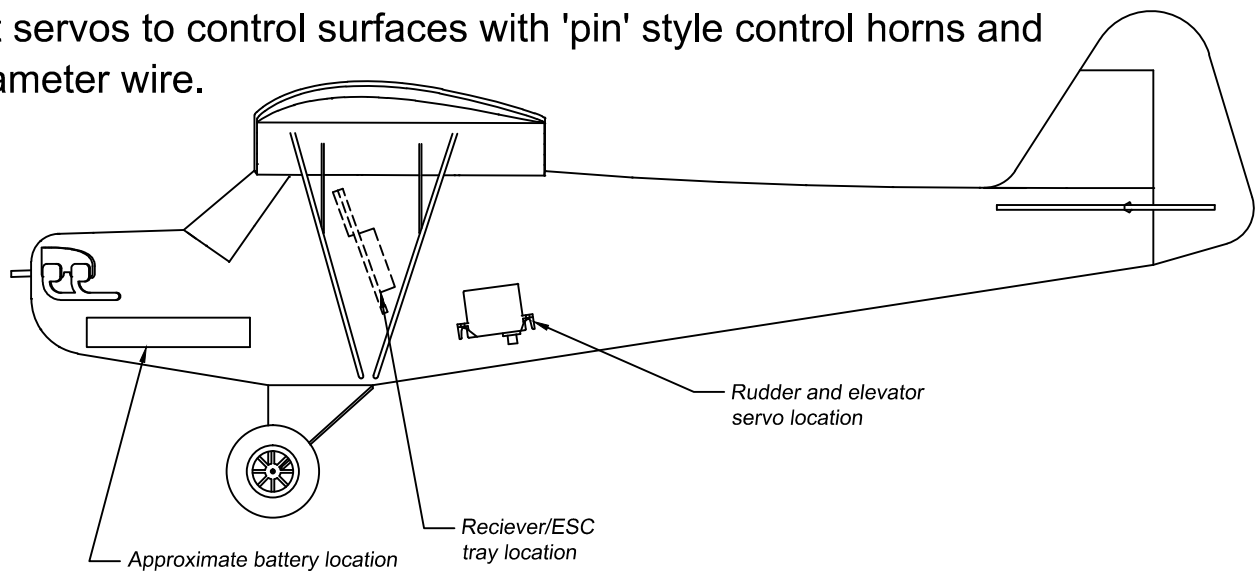

26. Secure the receiver and ESC to the removable receiver tray. Depending on the size of your electronics, the receiver and ESC can both be secured to the front of the tray or the receiver can be on the front and the ESC on the back of the tray.

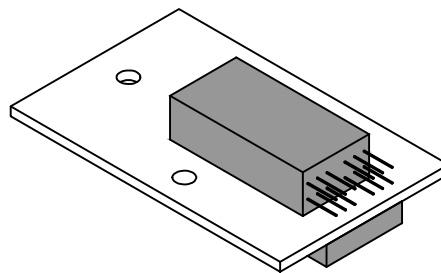
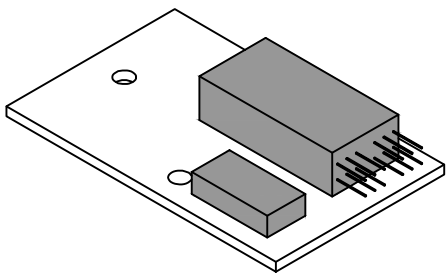

Set up and Flying

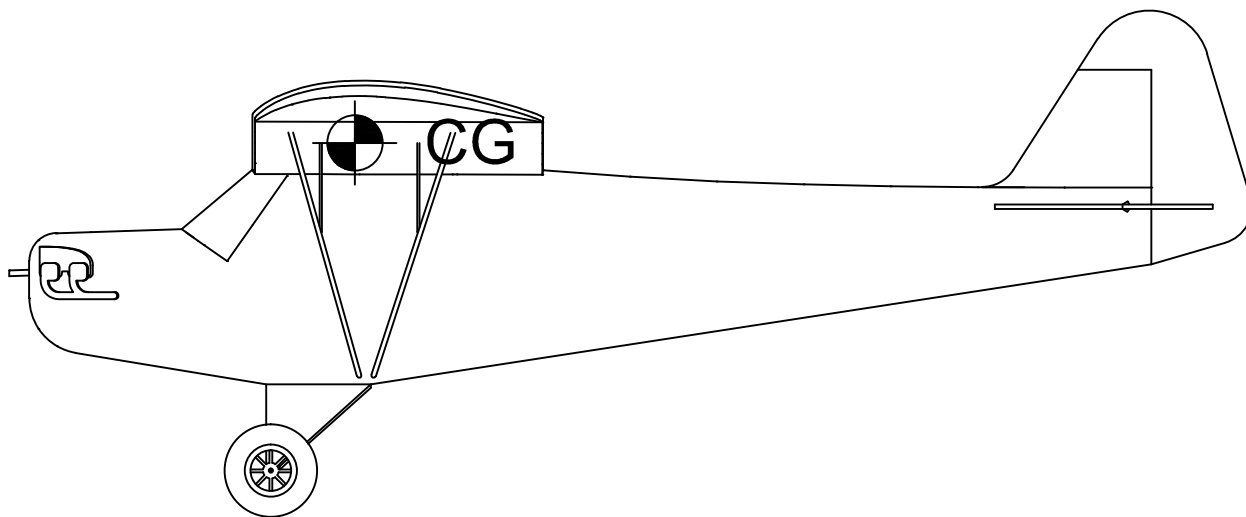

1. Balance your Piper J3 Cub on the front wing spar.
2. Set the throws for the control surfaces:
 - Elevator - 1/4" up/down
 - Rudder - 3/8" left/right
3. Due to the undercambered wing, the Piper J3 Cub will climb aggressively under full power. This can be countered by mixing in some down elevator with the throttle. Start at 5% down elevator and adjust as desired.
4. Setting up exponential throws (Expo) is a great way to help prevent over controlling your plane. A setting of 40% to 70% will provide smooth control response while still allowing for aggressive maneuvering.

