

Flight Line Plans™

EPC™ - Electronic Profile Controller

Features

- Six programmable motor run time settings; 10, 20, 30, 40, 50, 60 seconds
- Programmable speed setting
- Transition to cruise speed after 10 seconds (90% of maximum speed setting)
- Optional start on release for Hand Launch
- Optional 3 second soft start; transition from zero to maximum set speed over 3 seconds
- Optional 5 second delay before soft start to allow model to be placed for Rise off Ground
- Optional 5 second soft stop; transition from maximum set speed to zero over 5 seconds
- Optional 10 second soft stop; transition from maximum set speed to zero over 10 seconds
- Dual LED indicators for simple status and programming indication
- Easy set up and run via finger switch
- Internal non-volatile memory saves your programmed settings when battery is disconnected
- Low voltage cut off to prevent battery over discharging
- Lightweight, robust, easily mounted and interconnected

Specification

- Maximum motor current 2A to drive brushed motor
- Use with ONE lithium polymer cell only (4.2V)
- Low voltage cut off at 3.0V
- Size 11x15x5mm
- Weight ~1 gram

CAUTION

- Reverse polarity will PERMANENTLY damage the EPC and will not be covered by the standard manufacturer's warranty
- Damage resulting from any modifications to the EPC including changing of connectors will not be covered by standard manufacturer's warranty

Normal Operation

The EPC system is powered by connecting the Lipo battery connector to the EPC connector; no battery switch is necessary. The connections are shown below;

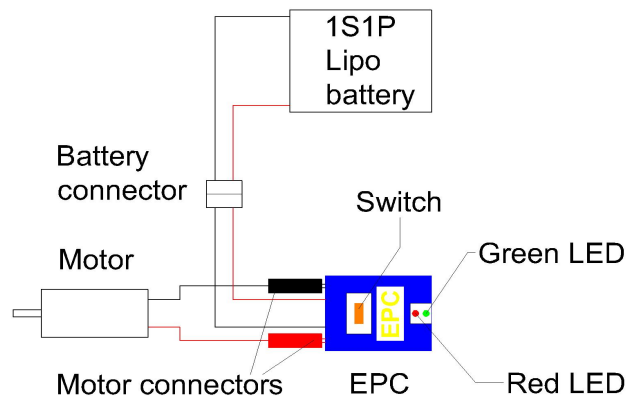

When the battery is connected the EPC will light the red LED for 0.5 seconds during initialisation and then the green LED will flash twice quickly indicating that idle mode has been entered. During idle mode the green LED will start a sequence of flashes. These flashes indicate the set motor Run time, one flash for 10 seconds, and 2 flashes for 20 seconds... 6 flashes for 60 seconds.

To start the timed motor run, simply press and release the switch. Once released the motor will begin to run and the green LED will light constantly until the motor run time has been completed. Note that the motor can be stopped at any point when the motor is running by pressing the switch again.

Should delayed soft start be set then the green LED will flash rapidly during the 5 second initial delay. Once the 5 second delay has passed the green LED will light constantly.

When the battery is discharged to 3.0V or below the motor will stop, the red LED will flash 5 times then stop. No further motor runs will be allowed. If the switch is pressed with a discharged battery connected then the red LED will flash 5 times to indicated a discharged battery.

Do NOT leave the EPC permanently connected to the battery. This will ultimately discharge the battery beyond minimum recommended levels.

Programming

Programming mode is entered by powering on the EPC and then holding down the switch for 10 seconds. After 10 seconds has passed the red LED will flash. Release the switch and the programming sequences will begin after a short delay.

De-powering the EPC immediately after the setting being changed has been actioned stops the Programming mode.

Programming is done by a sequence of LED flashes, these being a combination of long red flashes followed by a number of short green flashes

For example, setting a 20 second run you would wait for the following sequence...

Red – green – green – 2.5 second pause

To select the 20 second motor run, press and release the switch during the 2.5 second pause. Once selected the programming will continue with the next setting, in this case 'Speed setting'

For example (1), only setting a 40 second run you would wait for the following sequence...

Red – green – green – green – green – press and release the switch during 2.5 second pause – then de-power
The new run time is remembered when the EPC is next powered up

For example (2), only setting a speed setting increase you would wait for the following sequence,

Red – green – green – green – green – press the switch during 2.5 second pause
Red - red – green – press and hold switch until required speed is reached – release – then de-power
The new speed is remembered when the EPC is next powered up

Run time setting:

Red – green (1,1)	Push button to set 10 second motor run
Red – green – green (1,2)	Push button to set 20 second motor run
Red – green – green – green (1,3)	Push button to set 30 second motor run
Red – green – green – green – green (1,4)	Push button to set 40 second motor run
Red – green – green – green – green – green (1,5)	Push button to set 50 second motor run
Red – green – green – green – green – green – green (1,6)	Push button to set 60 second motor run

Speed setting:

The motor has 1600 possible speeds from zero to maximum. The speed is set by holding down the switch after the correct sequence of flashes (described below). **Caution:** When the switch is pressed the motor will run at the last saved speed; **keep clear of propeller.** Once the desired speed has been reached, release the switch to save that speed and stop the motor.

Red – red – green	Hold switch down to increase speed, release at desired speed. Green LED lights when maximum speed reached.
Red – red – green – green	Hold button down to decrease speed, release at desired speed. Green LED lights when minimum speed reached.

Soft start setting:

Power increases from zero to the set maximum speed over the first three seconds of the motor run. Soft start helps reduce excessive current draw and may prolong the life of the battery and motor. Delayed soft start can be used for Rise of Ground, where the model can be set to run then placed on the floor and left before the motor starts to run automatically.

Red – red – red – green	Soft start over 3 seconds
Red – red – red – green – green	Delayed soft start; 5 second delay before 3 second soft start
Red – red – red – green – green – green	Soft start off

Soft stop setting:

If set, the power will decrease from its maximum set speed to zero over the course of the last five/ten seconds of motor run. This can be used to give a gentle transition from powered to gliding flight.

Red – red – red – red – green	Soft stop over 5 seconds
Red – red – red – red – green – green	Soft stop over 10 seconds (only available when motor run is longer than 20 seconds)
Red – red – red – red – green – green – green	Soft stop off

Trouble Shooting

- EPC does not enter idle mode: Check battery connection and make sure battery is fully charged
- Motor only judders when switch first pressed: Current consumption probably too great for battery and tripping low voltage cut off. Choose a higher capacity or higher 'C' rated battery. Alternatively fit a smaller motor or propeller
- Motor stopped part way through a run: If red LED flashes 5 times the battery is flat; charge the battery
- Motor does not run when switch pressed: If red LED flashes 5 times the battery is flat; charge the battery
- Motor does not run when switch pressed: Battery very flat, red LED will not light; charge the battery
- EPC green LED lights constantly but motor does not run: Check motor connections.
Motor brushes may be worn or damaged: replace motor